

T8 LED 8FT QUICK BYPASS

40W LED Replacement for Fa8 or R17d 8FT T8 (T12) Fluorescent Lamps

Type B - Double-Ended, Ballast Bypassed

Description

The T8 LED 8FT is a 40W line driven (Type B, double-ended, ballast bypassed) linear T-LED replacement for an 8FT single pin (Fa8) or double recessed contact (R17d) T8 or T12 fluorescent lamp. Its built-in universal driver allows lamp operation at 100V ~ 277V.

R17d end cap makes this a double-ended lamp, allowing installation into both Shunted and Non-Shunted sockets in the case of the Double Recessed Contact . R17d lamps are ETL Classified for safe handling and can reduce installation time by half.

This lamp emits beautiful LED light over 330 of its surface. It has a Color Rendering Index (CRI) of >80 and delivers up to 5,500 lumens of usable light. The AIER T8 LED 8FT features a glass tube for improved optics and is available in 3000K, 3500K, 4000K and 5000K color temperatures.

The T8 8FT LED lamp may also replace a T12 fluorescent lamp.

This lamp is rated at 50,000 hours and is backed by a five-year warranty. It contains no mercury, allowing for non-hazardous waste disposal.

This is a Type B (ballast bypassed) lamp and does not support fluorescent ballasts or LED drivers. For a fixture with Double Recessed Contact (R17d) sockets, the R17d sockets can be either Shunted or Non-Shunted. All sockets are wired into AC line voltage.

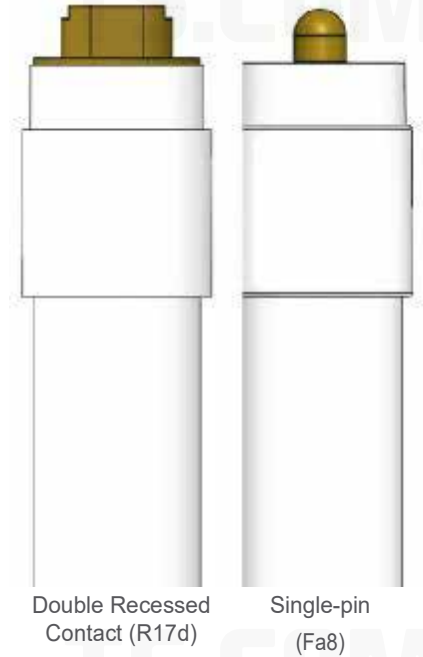

Features

- Replacement for T8 or T12 Lamps up to 75W with a 40W LED
- Quick Bypass (Type B, double-ended, ballast bypassed) Installation - supports line driven 100V-277V AC
- Universal Tombstone Technology (UTT) compatible with both Shunted and Non-Shunted Double Recessed Contact (R17d) sockets
- Delivers up to 5,000 lumens at > 80 CRI
- CCT 3000K, 3500K, 4000K and 5000K
- 50,000 hours life to L70 / 5-Year Warranty / P.C Shatter Guard

Ordering Information

Example: AR-T8-2400-A1

8ft T8 led tube light	T8 Double Recessed Contact (R17d) T8S Single-Pin (Fa8)	L Ballast Bypassed Supports (100V~277V)	96 inch tube	40W Up to 75W with 5,000lm (T8 or T12)	3000K 3500K 4000K 5000K	1st Generation	(Supports Shunted and Non-Shunted R17d tombstones)

Product Specifications

Illumination

Color Temperatures	3000K, 3500K, 4000K, 5000K
Delivered Lumens:	Up to 5,000lm
CRI	>80
Lumen Maintenance (L70)	50,000+ hours life

Electrical System

Power Factor	> 90%
Total Harmonic Distortion	< 15%
Input Voltage	100V ~ 277V
	50/60Hz AC Line Voltage
Total Power*	40W
Lamp Wattage Replaced	Up to 75W (T8 or T12)
Dimming	No

*

Physical	Double Recessed Contact (R17d)
----------	--------------------------------

Weight	0.55kg/pcs
Housing and Finish***	Glass, White, with PC. Shatter Guard
Optics	Optical PC Diffusion
Beam Spread / Beam Angle	330° / 180°

Environment

Ambient Operating Temp	-28 F to 113 F (-20 C to 45 C)
Ambient Operating Humidity	Dry and Damp Certified

Installation

Line Voltage	Fa8 socket or R17D socket (Shunted or Non-Shunted)
Ballast Installation	Yes (100V ~ 277V). NOT for use with ballasts or LED drivers.

Certifications & Qualifications

ETL(US and Canada)	Classified ETL Intertek
FCC****	Complies with Parts 15A/B
RoHS Compliant	Contains no lead or mercury

Listed	No category
--------	-------------

Warranty

Warranty	5 years
----------	---------

Product Dimensions

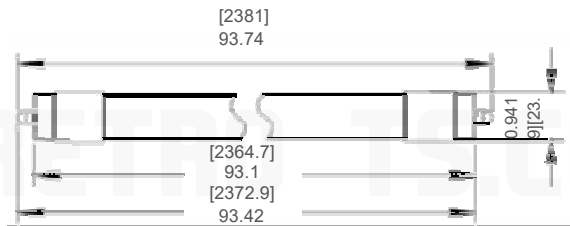

Application Notes

The 8ft T8 led lamp is compatible with UPS generators with output voltage range of 100~277VAC (50/60Hz). The distance between the generator and the lighting load should not exceed 1.7km. The UPS generator must energize the lighting loads only.

Lamp installation in the following conditions and applications *voids the product warranty*:

- Line voltage above 277VAC
- LED Drivers or with a ballast
- Gasketed, fully enclosed fixtures
- Installation in wet environments
- Installation in broken, cracked, dirty or rusted tombstones
- Improper wiring to the tombstones/lamp

* Total Power equals lamp power because the ballast has been bypassed or removed.

**** Operation is subject to the following conditions:
 (1) this device may not cause harmful interference, and
 (2) this device must accept any interference received, including interference that may cause undesired operations

CAUTION

Turn power off when installing the lamp.

CAUTION - IF THE LAMP OR LUMINAIRE EXHIBITS UNDESIRABLE OPERATION (BUZZING, FLICKERING, ETC.), IMMEDIATELY TURN OFF POWER, REMOVE LAMP FROM LUMINAIRE AND CONTACT MANUFACTURER.

Double-Ended Electrical Connection

T8 LED driven by 100V/277V 60Hz AC

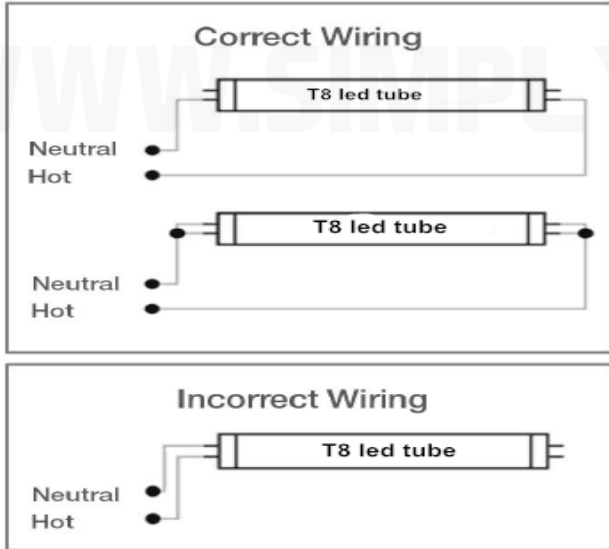

Socket Type

Double Recessed Contact (R17d)

Shunted or Non-Shunted
(Double-Ended Installation)



Single-Ended Electrical Connection

T8 LED driven by 100V/277V 60Hz AC

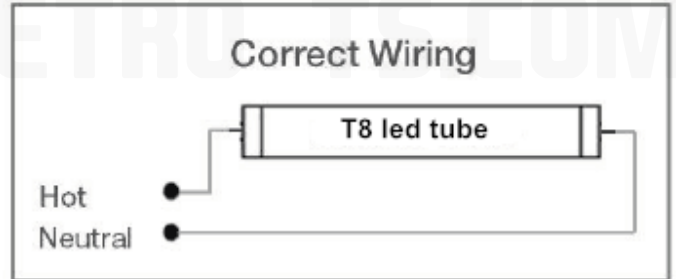

Socket Type

Single-Pin (Fa8)

Non-Shunted
(Single Ended Installation)

