

# COMBINATION ALARM & LED STROBE

PHOTOELECTRIC

MODEL **7030BSLA**

CAT 1038871



## AC POWERED WITH 10 YEAR SEALED BATTERY BACKUP

## INTEGRATED COMBINATION ALARM & STROBE LIGHT

Requires only one electrical box for 3 vital functions. Saves installation time and costs. One device includes strobe light and combination smoke/CO alarm.

## SMART STROBE

Separate flash patterns to distinguish between smoke and carbon monoxide.

## 177 CANDELA SYNCHRONIZED LED STROBE

Powerful 177 candela LED strobe light provides effective visual warning intended to waken hearing impaired residents. When multiple units installed, strobe is sync capable.

## 1 Hz FLASH RATE

60 flashes per minute rate.

## 10 YEAR SEALED BATTERY

Lithium long life battery to supply power to the alarm in the event of power failure for the 10 year life of the alarm. Sealed in the alarm housing to prevent tampering or removal.

## OPTIPATH 360 TECHNOLOGY™

Provides 360 degrees of direct access to the smoke sensing chamber.



Intertek  
3055574

Model 7030BSLA

# BRK®

THE PROFESSIONAL STANDARD

## 120V AC, 60Hz Wire-in with 10 Year Sealed Lithium Battery Backup

### Description:

The BRK Brands, Inc. Model Number 7030BSLA (CAT 1038871) is a wire-in, 120V AC 60Hz single and/or multiple station photoelectric smoke and carbon monoxide combination alarm with integrated 177 candela LED strobe light specifically designed for residential and institutional applications including sleeping rooms of hospitals, hotels, motels, public housing, dormitories and other multifamily dwellings. Model 7030BSLA is certified to CAN/CSA STD 6.19-01 & ULC STD S531 & ULC STD S526. The alarms are inter-connectable with up to 18 devices, of which 12 can be smoke alarms. The BRK 7030BSLA alarm features a photoelectric smoke sensing chamber, an electrochemical CO sensor, an integrated 177 LED candela strobe light, an 85dB horn and sealed lithium battery capable of providing backup power for smoke and CO functions alarm over 10 year alarm life without replacement. The Strobe Light is designed to provide deaf & hard of hearing individuals with a visual warning of fire or carbon monoxide dangers. The Smart Strobe has separate flash patterns for smoke/heat and carbon monoxide dangers. This helps a hearing impaired person better distinguish the danger present. The 177 candela LED strobe flashes at a rate of an average of 60 times a minute. The LED flash is also sync capable so when multiple units installed, strobes can flash in unison.

This alarm features two latching features and two silence features. Alarm Latch: Easily identifies initiating alarm even after alarm condition has subsided with blinking RED led pattern. Low Battery Latch: Identifies which unit is in low battery condition by blinking the green power light. Alarm Silence: Silence alarm for several minutes. End of Life: Silence alarm for 8 hours. Optipath 360 technology provides 360 degrees of direct access to the smoke sensing chamber. Other Contractor preferred features include a dust cover, easy twist-lock mounting bracket and a "Quick-Connect" wiring harness.



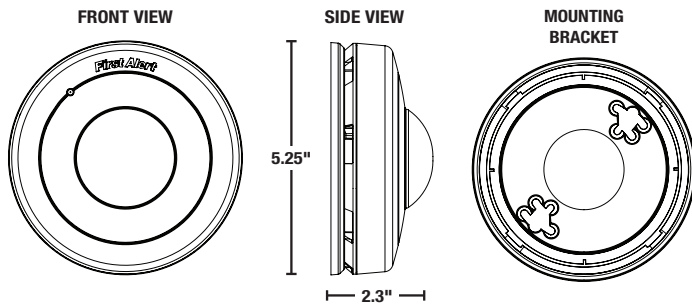

## ARCHITECTURAL AND ENGINEERING SPEC

The integrated strobe light & combination smoke & carbon monoxide shall be a BRK Model 7030BSLA and shall provide at a minimum the following features and functions:

1. A photoelectric smoke sensing chamber and electrochemical carbon monoxide sensor.
2. A 177 candela LED strobe light. The Smart Strobe shall have separate flash patterns to distinguish between smoke/heat and carbon monoxide dangers. When multiple units installed, strobe flash patterns will synchronize.
3. Fully screened sensing chamber to resist entry of small insects thereby reducing the probability of unwanted alarms.
4. Powered by 120V AC, 60Hz and have a sealed 10 year lithium battery backup for alarm and a solid state piezo horn rated at 85dB at 10 ft and be capable of self-restoring.
5. A visual green LED power-on indicator to confirm unit is receiving power or is in alarm.
6. A full function test button should check all alarm functions.
7. Two Latching features: Alarm Latch to easily identify initiating alarm after alarm condition has subsided. Low battery latch: to visually identify which unit is in low battery condition. Two Silence Features: Alarm Silence to temporarily silence nuisance alarms. End of Life: Silence alarm for 8 hours.
8. The unit shall be capable of operating between 40°F (4°C) and 100°F (38°C) and relative humidity between 10% and 95%.
9. The unit shall have a plug in connector and be capable of interconnection of up to 18 units with smoke, heat, CO alarms and relays, of which 12 can be smoke alarms.
10. The unit shall at a minimum meet the requirements of CAN/CSA STD 6.19-01 & ULC STD S531 & ULC STD S526.

## INSTALLATION OF ALARM

Installation of this smoke alarm must conform to all Canadian electrical code Interconnected units must meet the following requirements: wire gauge to be per local codes. It is recommended that all units be on the same fuse or circuit breaker. If local codes do not permit, be sure the neutral wire is common to both phases.

### THE PARTS OF THIS ALARM

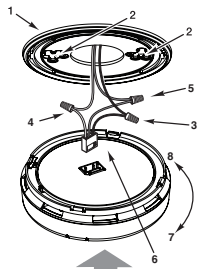

1. Mounting Bracket
2. Mounting Slots
3. Hot (Black) AC Wire
4. Neutral (White) AC Wire
5. Interconnect (Orange) Wire
6. Quick-Connect Power Connector
7. Turn this way to remove from bracket (Counterclockwise)
8. Turn this way to attach to bracket (Clockwise)

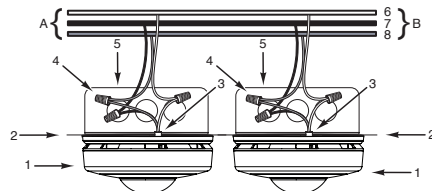

- A. 120VAC 60 Hz source  
 B. To additional units; Maximum = 18 total (Maximum 12 Smoke Alarms)

1. Alarm
2. Ceiling or Wall
3. Power Connector
4. Wire Nut
5. Junction Box
6. Neutral Wire (Wht)
7. Interconnect Wire (Orange)
8. Hot Wire (Blk)

## TECHNICAL SPECS

Alarm Dimensions:	5.2" dia. x 2.3"H
Weight:	10.6 oz
Operating Voltage:	120V AC 60Hz with 3V Sealed Lithium Battery Backup for alarm.
Operating Current:	Alarm 0.8 A
Temperature Range:	40°F (4°C) to 100°F (38°C)
Humidity Range:	10% to 95% relative humidity (RH)
Audio Alarm:	85dB at 10 feet
Test/Silence:	Electronically simulates smoke condition, causing the unit to alarm. Press and hold test/silence button.
Alarm Reset:	Automatic when smoke clears
Interconnections:	Up to 18 units of First Alert or BRK Smoke, CO and Heat Alarms. Maximum number of 12 smoke alarms.
Smoke Sensor:	Photoelectric
CO Sensor:	Electrochemical
Strobe Light:	177 candela LED strobe
Indicator Lights/Sounds:	
AC Power:	Constant Green LED
DC Power:	Green LED flash, once per minute
Local Alarm:	Audio alarm, steady flashing strobe and Red LED in synch with horn pattern
Silence:	Approximately 9 minutes Smoke initiating alarm, approximately 4.5 minutes CO initiating alarm, 8 hours End of Life
Alarm Latch:	Red LED flashing 2 seconds on, 2 seconds off
Low Battery Latch:	Green LED flashing 2 seconds on, 2 seconds off
End of Life:	3 short chirps with 5 Green LED flashes once per minute
Listing:	Certified to CAN/CSA STD 6.19-01 & ULC STD S531 & ULC STD S526

## SHIPPING SPECS

Individual Carton Dimensions	5.25" L x 3.0"W x 5.25"H
Weight	0.87 lbs.
Cube	0.05 ft <sup>3</sup>
UPC	0 29054 01814 4
Master Carton Dimensions	5.75" L x 19.13"W x 6.0"H
Master Pack	6
Weight	5.63 lbs.
Cube:	0.38 ft <sup>3</sup>
I2of5:	600 29054 01814 6
Pallet Information	
Cases per Layer	18
Number of Layers:	7
Cases per Pallet:	126
Units per Pallet:	756
Cube:	59.26 ft <sup>3</sup>
Weight:	784 lbs.



©2016 BRK Brands, Inc.  
All rights reserved

www.brkcanada.ca  
www.firstalert.ca